Pantera Electronics Electric Parking Brake Controller Installation Manual

Rev3

This 2 wire EPB Controller will operate 2 **Tesla Model 3**, 2 wire calipers with the integrated electric parking brake actuator.

This 2 wire EPB Controller will operate 2 **Tesla Model S**, 4 wire electric parking brake calipers.

Other 2 wire EPB calipers may operate as well but has not been verified.

— The 4 pin connectors for Model S calipers and the 2 pin connectors for the Model 3 calipers and are available from Pantera Electronics, the 2 pin connectors may fit other calipers as well.

Input Requirements: Operating voltage 9.0 to 15.5 V
Maximum current 15 Amps (BAT terminal)

***READ THIS MANUAL THOROUGHLY BEFORE STARTING THE
INSTALLATION. IF YOU DO NOT UNDERSTAND THE CONTENT DO
NOT ATTEMPT TO INSTALL THE ELECTRIC PARKING BRAKE
CONTROLLER.***

***IT IS MANDATORY TO USE PROFESSIONAL AUTOMOTIVE
WORKMANSHIP FOR INSTALLING THE ELECTRIC PARKING
BRAKE CONTROLLER.***

***DO NOT APPLY ELECTRIC PARKING BRAKE WHILE CAR IS IN
MOTION IN EXCESS OF 10 MILES PER HOUR.***

***THERE ARE NO INTERLOCKS TO PREVENT APPLYING THIS
PARKING BRAKE SWITCH AT ANYTIME.***

— ***THE ELECTRIC PARKING BRAKE CONTROLLER MAY CLOSE
BOTH CALIPERS THE FIRST TIME IT IS POWERED.
DO NOT ALLOW ANYTHING TO BE BETWEEN THE ROTORS AND
CALIPER PADS THE FIRST TIME POWER IS APPLIED,
INCLUDING FINGERS !***

***DO NOT CONTACT PANTERA ELECTRONICS CONCERNING
OPERATION OF THE TESLA CALIPERS.***

***IF YOU DIDN'T FINISH HIGH SCHOOL DO NOT ATTEMPT THIS
INSTALLATION.***

Electric Parking Brake Controller Features and Operation

- > The **Push Button** version requires one momentary switch with normally open contacts. Press once to “SET” and press again to “RELEASE” the electric parking brake.
- > Independent monitor and control for left and right calipers with connections for green LED indicator for “RELEASE” and red LED indicator for “SET” parking brake.
- > The EPB Controller closes the caliper to a specific pressure and releases to a specific distance. EPB Controller automatically compensates for any brake pad wear.
- > Simple installation with Pantera Electronics installation kit which includes mating connectors, terminals for the calipers and 25 feet (7.62 meters) of 2 wire cable for Tesla Model 3 calipers.
- > LED indicators for proper installation and verification of each caliper operation.
- > Optional push button with internal LED indicator, RED for “SET” and GREEN for “RELEASE”.

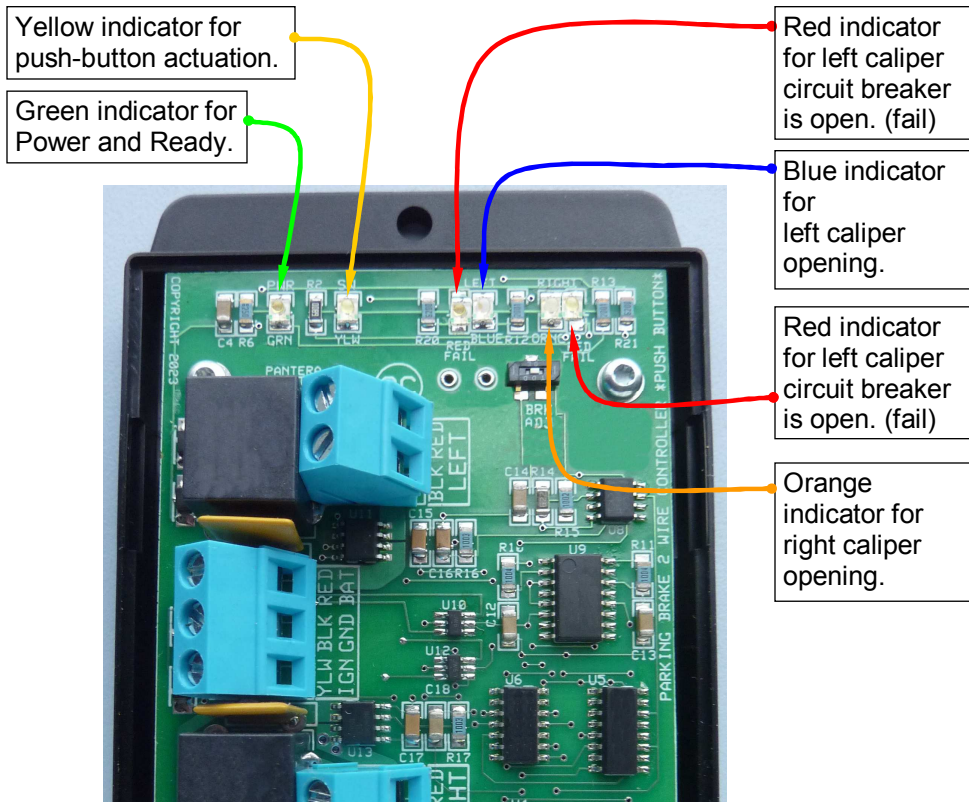

EPB Caliper / Connector Wiring

The wire size between the EPB controller and the calipers **must be 16 AWG, not larger or smaller AWG.**

Recommended automotive brake cable is available from Pantera Electronics.
(2 wires, 16 AWG, fully annealed copper for flexibility)

EPB Installation Kit

Part # EPB2-KIT

An installation kit from Pantera Electronics consists of the following:

- (1 length) 2 conductor, 16 AWG wire brake cable, 25 feet long. (7.62 Meters)
- (2) Connectors for Tesla Model 3 caliper.
- (4) Terminals with seals for the connectors.

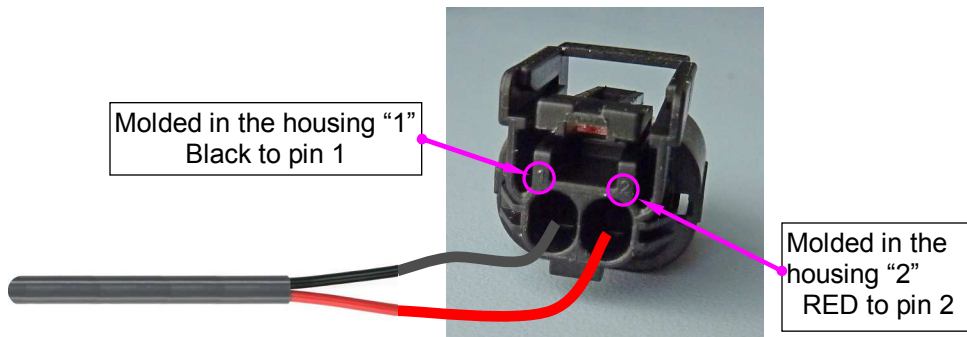
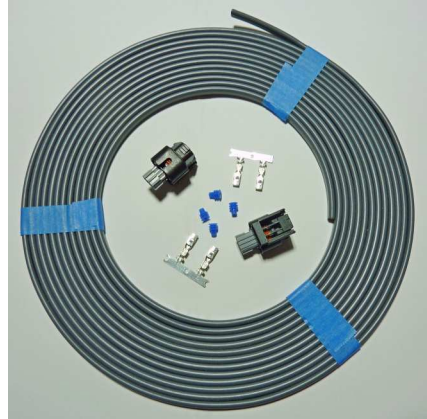

Ring terminal, blue for 14-16 AWG wire and internal/external tooth lock washer for grounding wires to the chassis.



Installing Wires in a 2 wire Connector

Strip a length of the wire to accommodate the seal and the terminal. Do this for both wires.

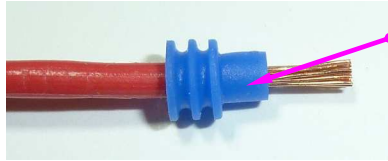
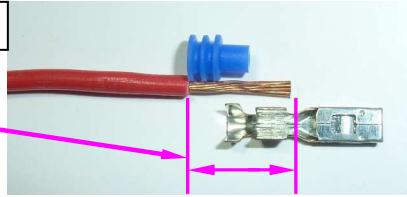

Slide the seal on the stripped section of the wire.

Assemble the terminal on the wire with seal.

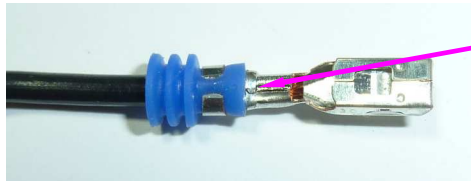
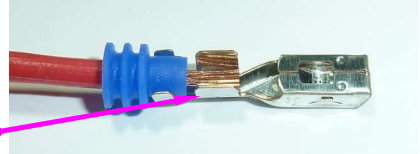

Crimp the assembly so that the seal and terminal look like in the picture.

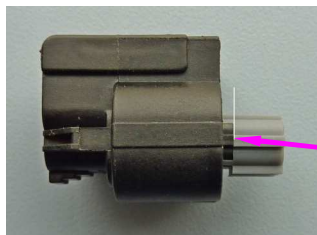

The connectors should be ready for terminal insertion with the grey part extended as in the lower picture.

If not the grey part of the connector has to be slid out to a position for inserting the terminals but no further.

The connectors should be already ready for terminal insertion with the grey part extended. Use a small screwdriver to pry the grey part outward.

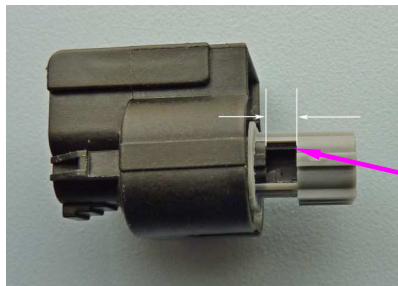
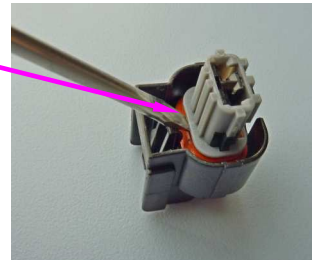

When the grey part is in the correct position a detent is felt. Then it is in the position to accept the terminals. Note the space from moving the grey part.

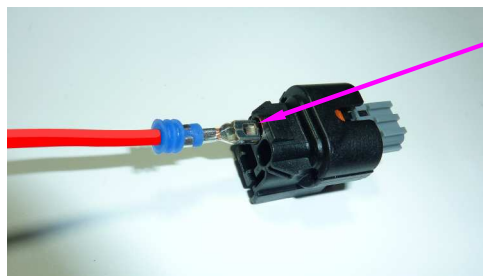

Insert the red terminal in this hole with the connector retainer down.

Insert the terminal facing in the direction as in the picture.

Installing Wires in a 2 wire Connector Continued

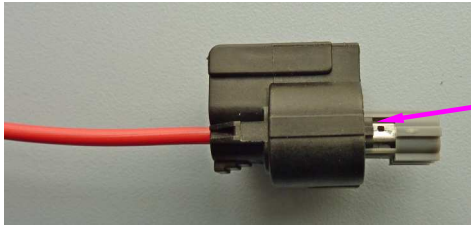

Push the terminal into the connector until it stops and the square hole in the terminal can be seen.

Insert the black terminal in this hole with the connector retainer down.
Insert the terminal facing in the direction as in the picture.

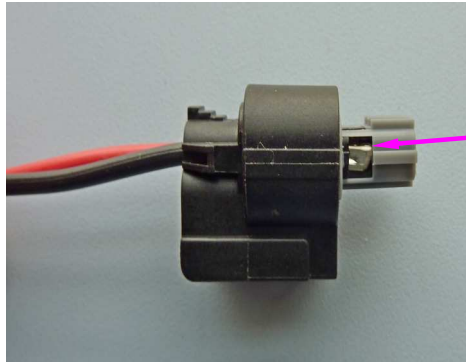
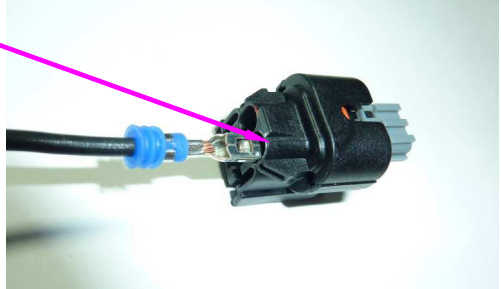

If the terminal does not push to the end it may be caught on the edge of the connector as shown in picture.

Use a small screw driver to push the terminal into alignment and push the terminal in further.

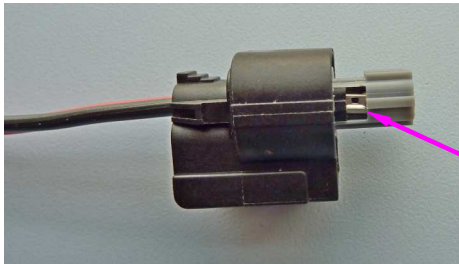
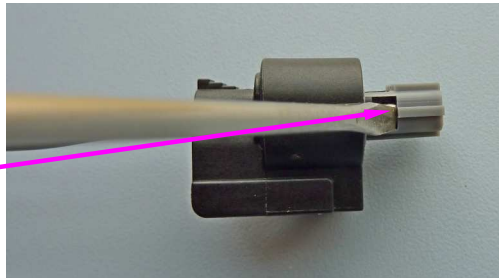

Push the terminal into the connector until it stops and the square hole in the terminal can be seen.

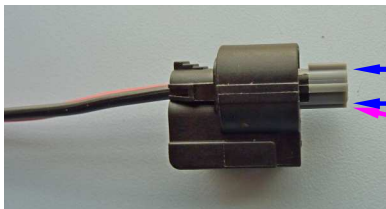

PUSH

Press the grey part into the rest of the connector so that it's flush on the end of the connector.

Disassembling the connector for removing wires from the 2 wire connector.

To disassemble the connector to remove a wire with a terminal do the following.

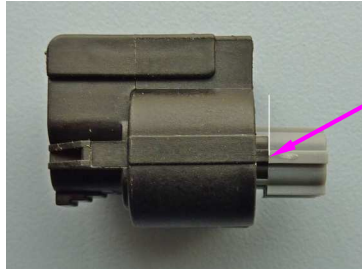

The grey part of the connector has to be slid out to the position for removing the terminals, but no further.
This is the connector as received

Use a small screwdriver to pry the grey part outward to loosen.

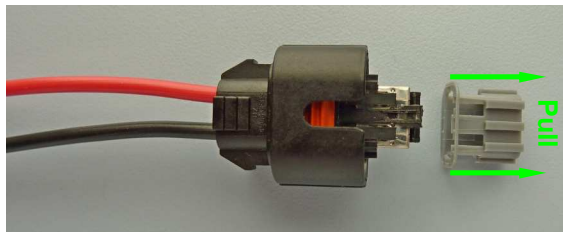
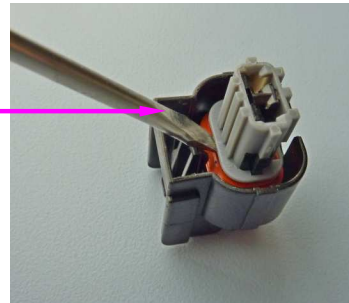

Pull the grey part completely from the rest of the connector.

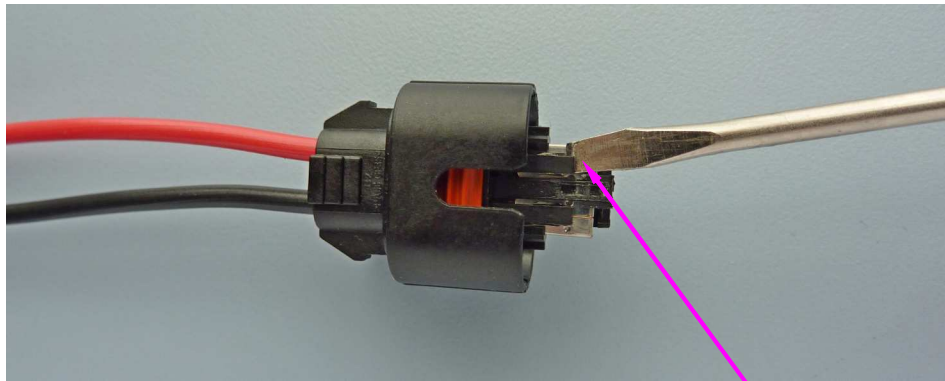

Use a small screwdriver to pry the small lever part upward and gently pull on the wire.

The lever part rests in a square hole in the terminal and must be raised enough out of the hole.

If the terminal doesn't move lift the lever a little more.

EPB Caliper 4 Terminal Connector for 2 wires.

The wire size between the EPB controller and the calipers **must be 16 AWG, not larger or smaller AWG.**

Female terminal for the connector.

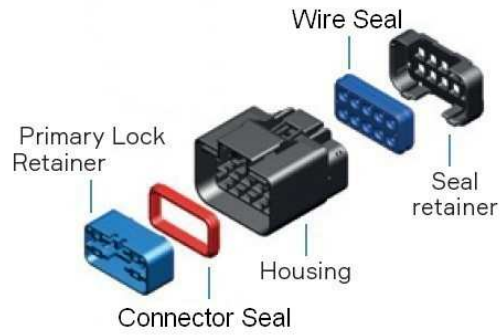

Female connector for Tesla/Brembo brake caliper

EPB Installation Kit
Part # EPB2/4-KiT

An installation kit from Pantera Electronics consists of the following:

(1 length) 2 conductor, 16 AWG wire brake cable, 25 feet (7.62 Meters) long.

(2) Compatible connectors for the Tesla / Brembo caliper.

(8) Terminals for the caliper connectors.

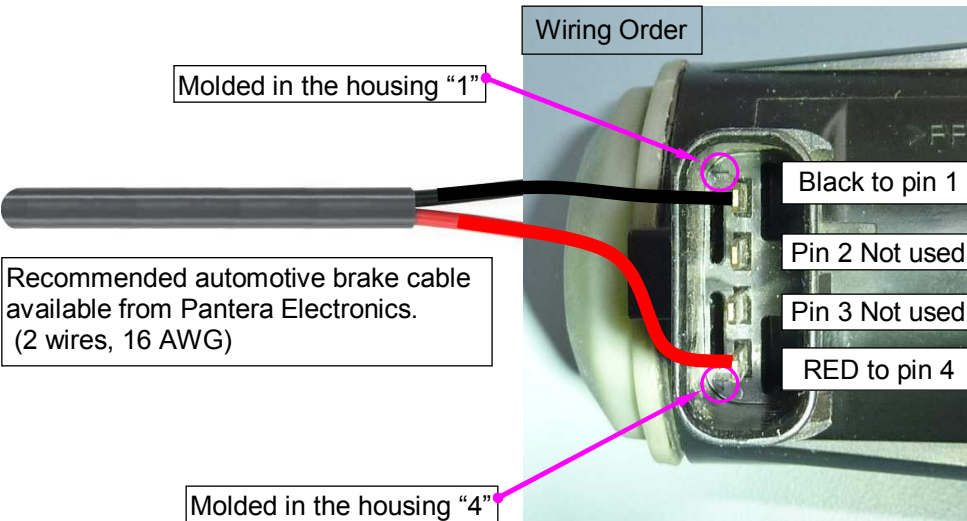
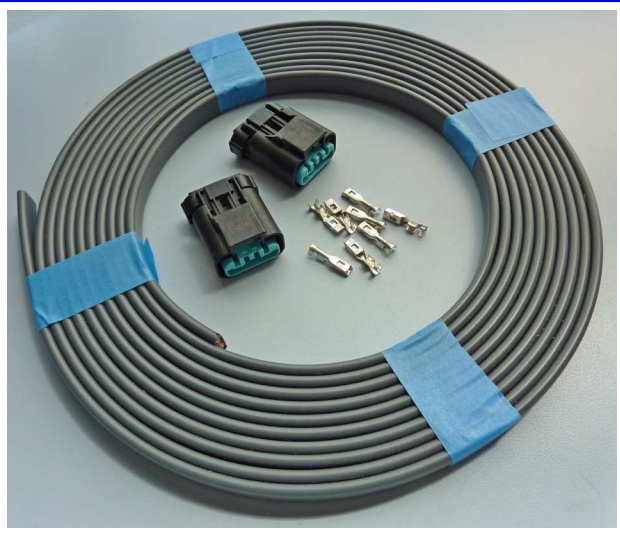

Installing Wires Into the Connector

Crimp a terminal on each wire of the cable. Insert the wire with terminal into the HOUSING. Note the correct origination of the terminal.

Do this for all 4 wires.

A click will be heard when the terminal seats properly.

Slide the WIRE SEAL over the wires.

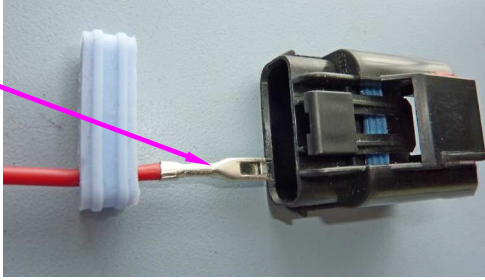

Slide the WIRE SEAL and press into the HOUSING.

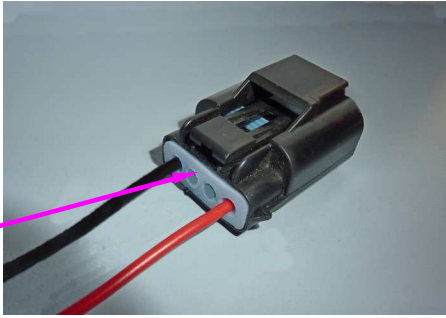

Slide the SEAL RETAINER and press to the HOUSING, a click will be heard when the SEAL RETAINER is latched.

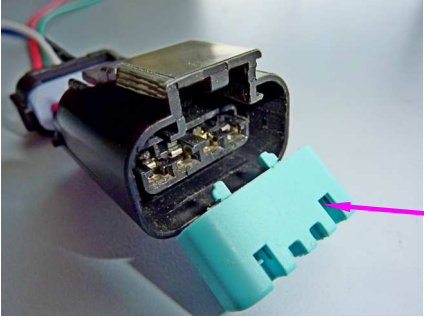
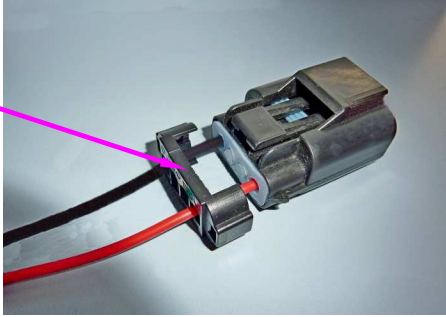

Position the Primary Lock Retainer as in picture.

Press the PRIMARY LOCK RETAINER over the Housing until it seats flush with the end of the HOUSING.

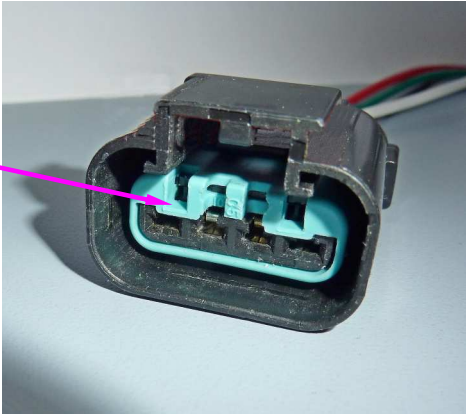

Disassembling the Connector or Removing Wires From the Connector

To disassemble the connector or if a wire with a terminal needs to be removed from the housing do the following.

Remove the WIRE SEAL by prying the end of the WIRE SEAL inserting a small screw driver in the place as indicated in picture.

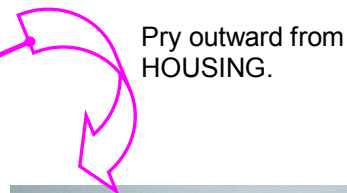
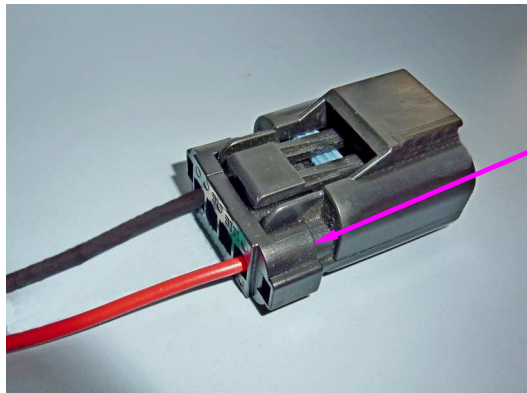

Pry outward from HOUSING.

Pry the WIRE SEAL out of the HOUSING and slide back.

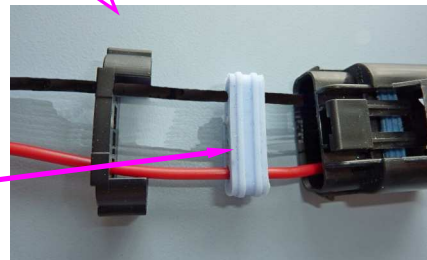

Remove the PRIMARY LOCK RETAINER by grasping in the center as in picture. Gently rock the PRIMARY LOCK RETAINER while pulling.

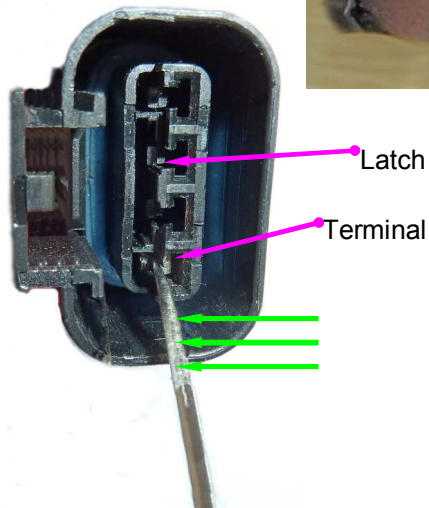
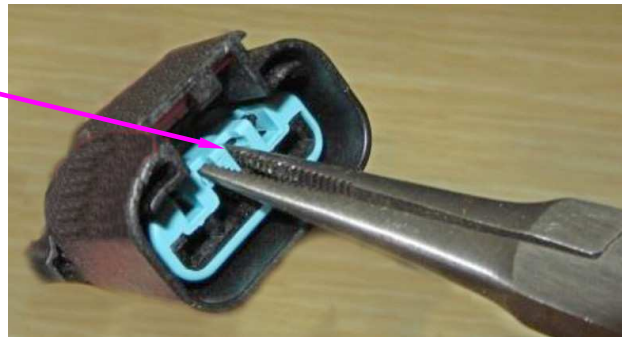

The wire terminal is retained in the HOUSING by a latch that must be moved slightly. It can be gently pushed with a paper clip wire or a pick.

Push in the direction of the green arrows and pull the terminal from the backside.

Mounting Dimensions (drawing is not to scale)

This enclosure is NOT sealed and NOT rated for wet conditions or impact from debris. Mounting location should be in a protected area.

RTV sealant can be used but condensation may form internally so leave some area not sealed as a vent.

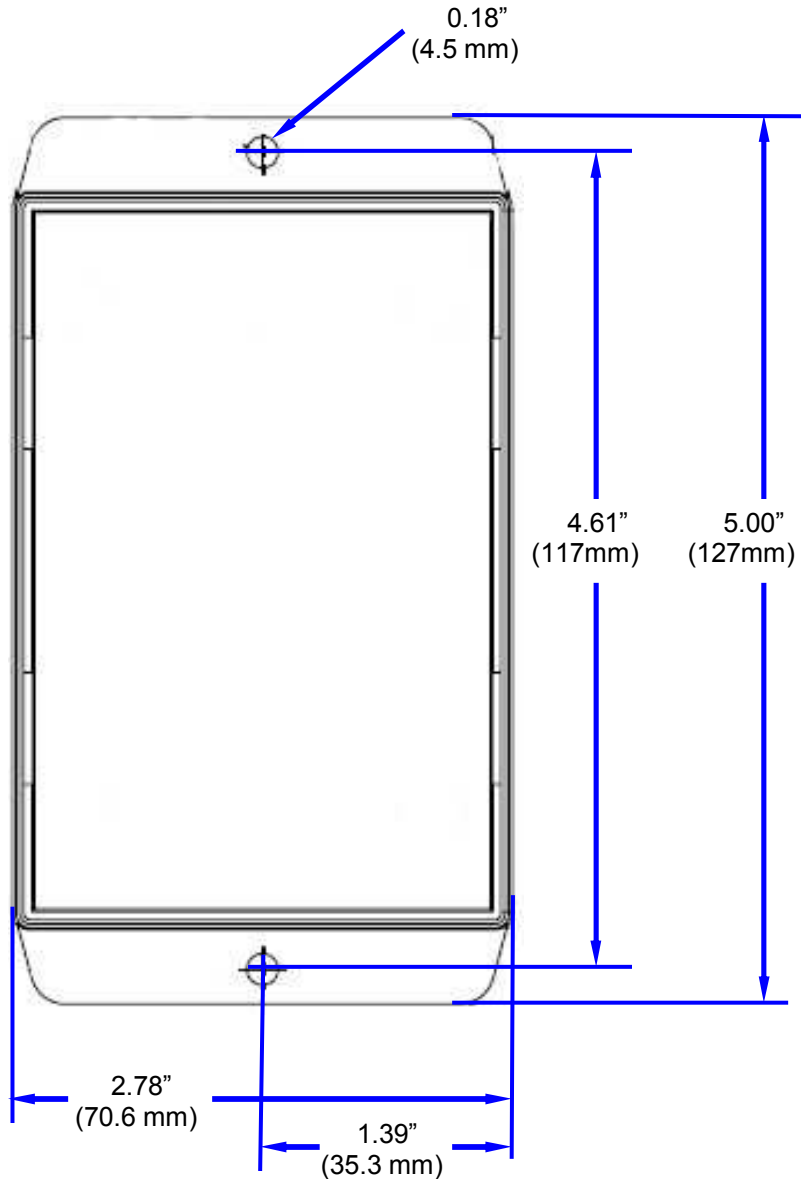

Opening the Enclosure

There are 4 internal latches that retain the lid to the base of the enclosure. The latch positions are located on the sides of the lid indicated by small round mold pin marks. (at arrows in picture)

Squeeze the sides of the lid approximately center on the side and pull the lid from the base.

To replace the lid align the latches to the slots in the base and press together.



NOTE: It's important to keep this installation manual for future reference since revisions to this product change the contents of the installation manual.

Disclaimer

The products from Pantera Electronics have been design and manufactured with the best quality components known to the engineer. The installation instructions have been written to assist the owner in the proper use and installation of the products. Pantera Electronics can not be held responsible or held liable for the interpretation or incorrect implementation of the products.

Disconnect the Battery by removing the negative (-) or ground cable from the battery terminal before connecting the Electric Parking Brake Controller.

EPBC Wiring and other important installation notes.

The wiring between the EPBC and the calipers must 16 AWG, not larger or smaller AWG. A 25 foot (7.62 Meters) long 2 wire cable brake cable and compatible connectors for the Tesla Model 3 calipers are available from Pantera Electronics in the Installation Kit for Tesla Model 3 calipers.

Connect the YELLOW "IGN" terminal to a circuit with a 18 AWG wire in series with a 1 Amp fuse. This circuit should be the ignition circuit energized with the ignition switch "ON".

The ground wire, BLACK must be 16 AWG with a ring terminal and internal/ external tooth lock washer mounted to the chassis on a paint free area.

Connect the RED "BAT" terminal to a circuit with a 16 AWG wire in series with a 20 Amp fuse. **The RED "BAT" connection is required to be powered all the time, this is necessary.** When the ignition is "OFF" the current consumption is very low and will not be an issue.

The RED "BAT" terminal maintains the memory for the EPBC to remember if the calipers are open or closed. When this terminal is not powered then re-powered the EPBC will not "know" in what position the calipers are in.

It may take several cycles of operating the calipers before the EPBC is synchronized with both calipers.

If the EPBC does not synchronize with both calipers then there maybe a problem with the calipers.

The Tesla calipers may possibly have broken gears that would not allow proper movement of the calipers.

ONLY LED indicators can be connected to the "SET" "RED" and "RLSE" "GREEN" terminal block positions. Incandescent indicators will not operate. The "SET" "RED" and "RLSE" "GREEN" terminal block connections are current limited allowing 2 wire bidirectional LED's to be directly connected without a resistor.

The terminal is labeled as "COM" "GREY" is NOT the same as chassis ground and should not be connected to chassis ground.

>>>> Inter-locks <<<<

Do not add electrical modifications or interlocks to any of the caliper cable wires, the caliper wires MUST wire directly to the controller. This can permanently damage the EPB Controller !

Terminal Layout

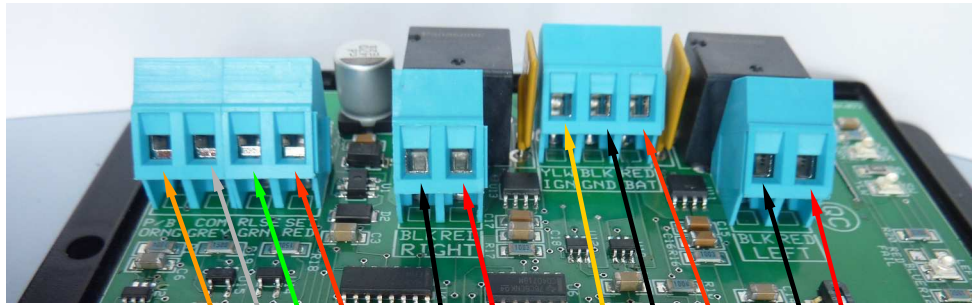

Connect "ORNG" "P/B" to the "NO" terminal on the push-button switch.

Connect "GRY" "COM" to the "C" terminal on the Push-Button and indicator.

Connect "RLSE" "GRN" to the "G" terminal on the push-button.

Connect "SET" "RED" to the "R" terminal on the push-button.

Connect to RED, BLK wires from RIGHT caliper

Connect YELLOW 18 AWG wire to "IGN" fuse that is "on" in the ignition position

Connect to RED, BLK wires from LEFT caliper

Connect RED 16 AWG wire "BAT" to a fuse that is **powered at all times**.

Connect a BLK 16 AWG wire "GND" to chassis ground with ring terminal and lock washer to GND.

EPBC Wiring Layout

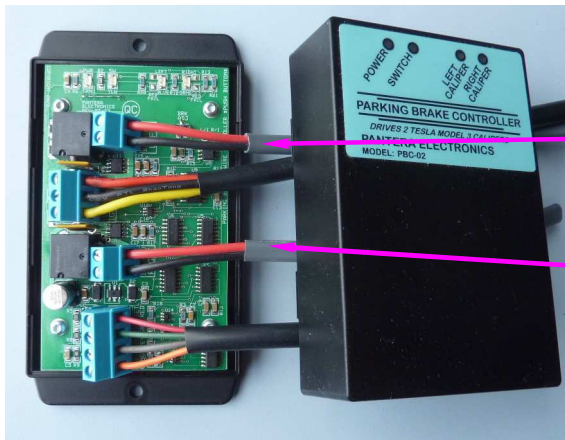

The brake cable in the picture is the 2 wire cable that is provided in the Pantera Electronics Installation Kit for 2 wire calipers.

Installing Terminals

Crimp the terminals to Red, Green, Orange and 2 Grey wires for connection to the EPB Controller.

Before pressing the wire terminals on the push button terminals, pry the spring part of the terminal to lower the force required to push the terminal on the switch terminal.

The reason to do this is because if the wire terminals have to be removed from the push button switch and the force is great it will pull out the center section of the pushbutton switch.

This can be permanent damage to the pushbutton switch.

Spring part of terminal

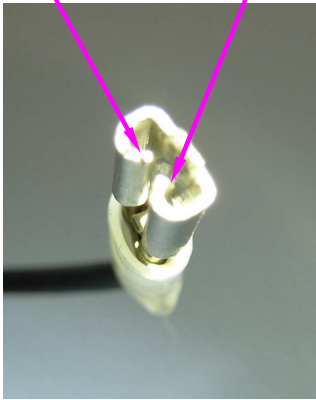

Pry the spring part of terminal with a small screw driver

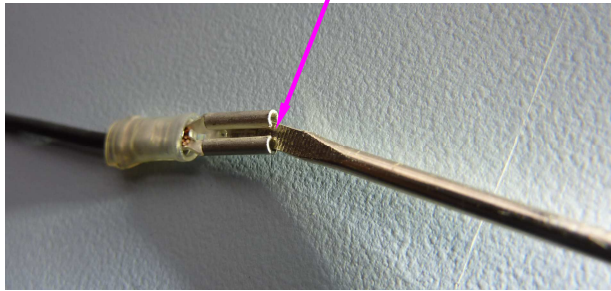

Center section is orange color

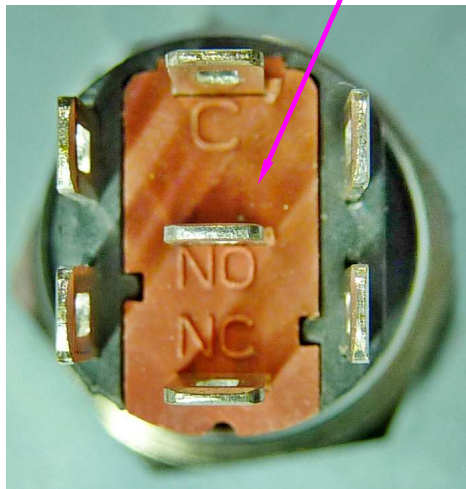

EPB Controller Push-Button Switch Wiring with dual color LED Ring

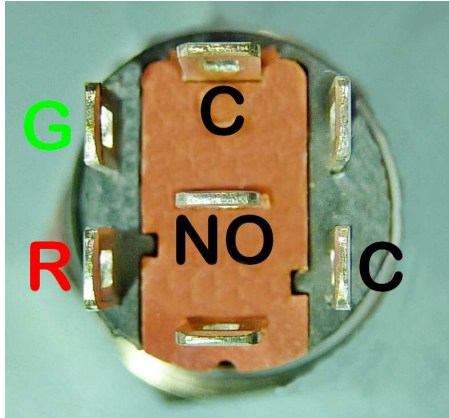

There are 7 terminals on the push-button switch. Only 5 terminals are needed for the EPB controller.

"G" terminal

"R" terminal

"C" terminal

"C" terminal

"NO" terminal

Mounting hole size 5/8" (0.625")

Use 18 AWG RED wire to connect push-button "R" terminal to "SET" "RED" on EPBC.

Use 18 AWG GREEN wire to connect push-button "G" LED terminal to "RLSE" "GRN" on EPBC.

Use 18 AWG wire to connect push-button "C" terminal to "COM" "GRY" on EPBC.

Use 18 AWG wire to connect push-button "NO" terminal to "P/B" "ORNG" on EPBC.

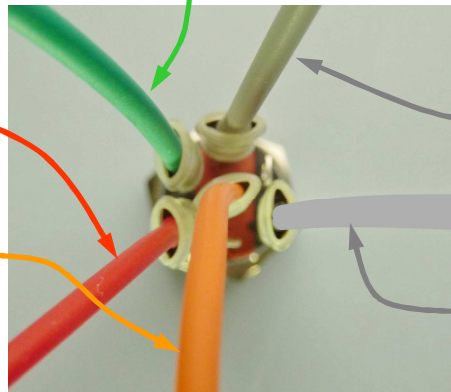

Use 18 AWG wire to connect push-button "C" terminal to "COM" "GRY" on EPBC.

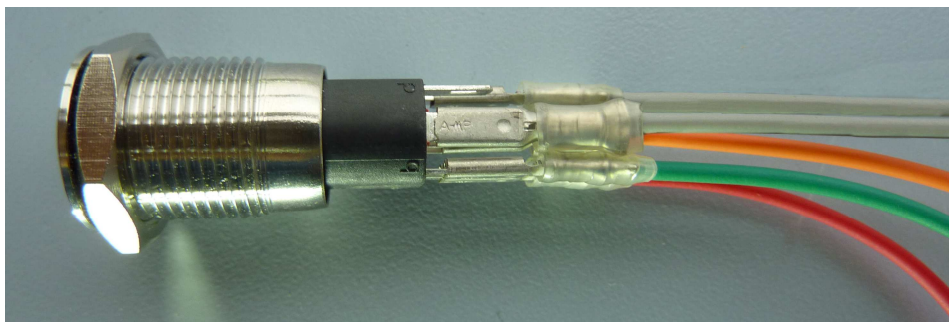

Push Button Electric Parking Brake Controller Testing

The calipers *MUST* be installed and disk rotor in place *BEFORE* testing the EPBC.

1. Re-connect battery negative (-) or ground cable from the battery terminal.
2. When the EPBC is first powered the indicators may be illuminated randomly, this will self-correct after the EPBC is cycled.
3. The BLUE internal indicator is for the left caliper and an ORANGE internal indicator is for the right caliper. These indicators illuminate when the caliper is opening. When the calipers stop moving the indicators will be OFF.
4. Press the push button switch, the YELLOW internal indicator should flash once per push-button press. This verifies proper wiring to the push-button switch.
5. Press the push button switch this should cause both calipers to move clamping the disk. When the brake pads contact the disk the motor will continue to operate until pressure is developed.

The RED indicator in the push-button switch will illuminate when both calipers are "SET".

6. Press the push button switch again this should cause both calipers to open. The caliper will open a preset **distance of approximately 0.1" (2.5mm)** and should be enough to allow the disk to rotate freely. Verify that both blue and orange indicators *are* illuminated until the caliper stops, this verifies both calipers opened.

The GREEN indicator in the push-button switch will illuminate when both calipers "RELEASE".

7. Press the push button switch again this should cause both calipers to close or "SET" and the RED indicator to illuminate then the calipers have clamped the disk at the preset pressure.
8. Try to move the car by manual pushing or using the engine and first gear to over-come the EPBC. If resistance is felt then the EPBC is functioning properly.
9. Press the push button switch again this should cause both calipers to open.
10. Try to move the car by manual pushing or using the engine and first gear to over-come the EPBC. If resistance is no longer felt then the EPBC is functioning properly.
11. Testing complete.

Electric Parking Brake Controller Maintenance Operation

The caliper can be opened further than in normal operation.
This would be for maintenance or removal of the caliper from its mounting.

1. Press the push-button to operate the calipers, if pressing the push-button closes the caliper allow it to close. After the caliper is closed press the push-button and continue to press the push-button approximately 2 to 3 times per second until the caliper is open enough to remove it.

3. Power should be removed from the EPB controller so that there is no possibility of it closing accidentally.

4. After the caliper is replaced on the mounting re-apply power and press the push-button until both calipers synchronize with the push-button.

—

—